

DALLAS

# MAGNESOL® XL

"Shortening Filter System"

**FILTERING HAS NEVER BEEN THIS EASY!!!**

**Low-Boy®**  
*Compact & Convenient*

**FINALLY!**

Whether your fried foods produce a heavy crumb load or just really tear up your frying oil, the powerful **Low-Boy®** Shortening Filter can be custom tailored to get the most from your frying oil.

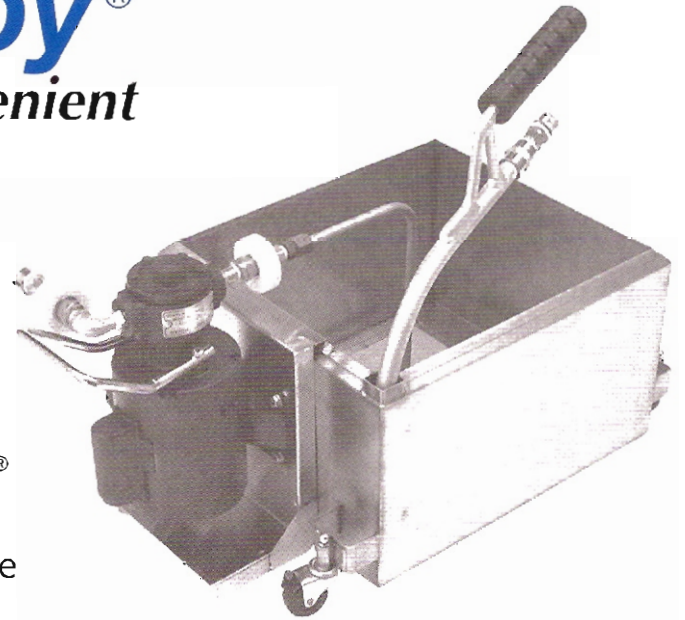

## MAXIMUM FILTERING FLEXIBILITY

*Reversible Models Available*

### CHECK THESE FILTER OPTIONS:

Models J-50, J-60 and J-95

Models J-50S, J-60S and J-95S

Models J-50S, J-60S and J-95S

✓ **FILTER LEAF SCREEN: \***

A durable stainless steel filter screen provides the highest flow rate and eliminates filter paper. The screen will not rust or tear under normal conditions.

✓ **FILTER PAD ENVELOPE:**

A thick "pre-powdered" cellulose pad containing **MAGNESOL® XL** filter powder provides maximum oil freshness and clarity combined with the ultimate in convenience.

✓ **FILTER PAPER ENVELOPE: \***

A high quality paper envelope filters fast and easy. This option combines the lowest initial cost with the ability to upgrade later to the filter pad envelope or filter screen.

## \*USE MAGNESOL® XL

When using the Filter Leaf Screen or Filter Paper Envelope be sure to use **MAGNESOL® XL "Shortening Saver"** Filter Powder. **MAGNESOL® XL** helps filter out the finest crumbs and sediment and removes soluble impurities that cause off-flavors and odors. Frying oil stays fresh longer while foods fry up light, crisp, and golden delicious!

# DALLAS

## THE **Low-Boy**<sup>®</sup> SHORTENING FILTER is assembled in components for easy operating, cleaning and storing.

**1**

### PUMP & MOTOR ASSEMBLY

Heavy duty motor and high capacity pump provide powerful suction and better filtration. Reversible motors are available for each model.

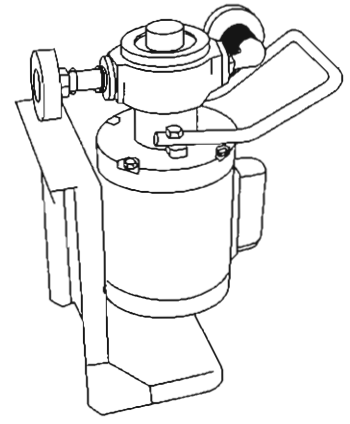

**2**

### FILTER ASSEMBLY

Filter assembly is simple and durable. Designed for maximum flexibility, it allows the use of filter leaf screen, filter pad envelope, or filter paper.

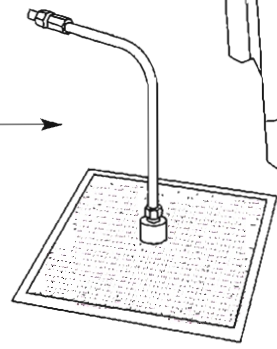

**3**

### HOSE & NOZZLE ASSEMBLY

Quickly connects to Pump and Motor Assembly and provides safe and easy handling of shortening.

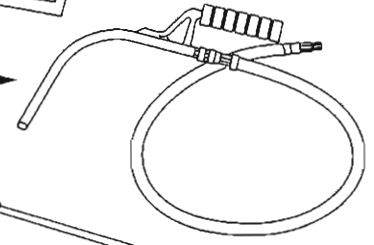

**4**

### FILTER TANK

Durable tank with tough rubber snap-on casters. Tank sizes available for use with almost any size fryer. Capacity rating allows for 40% safety margin.

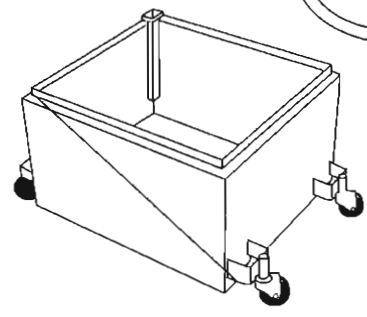

TANK SAFETY COVERS ARE AVAILABLE.

## SPECIFICATIONS

Component	Tank Capacity (Rated)	Pump Capacity	Motor Capacity	Electrical (with overload protector)	Tank Dimensions	Shipping Weight
<b>Low-Boy</b> <sup>®</sup>						
Model J-50*	50 lbs.	5 GPM	1/3 HP	115V/60 Hz	24" x 12" x 8 1/2"	72 lbs.
Model J-60*	60 lbs.	5 GPM	1/3 HP	115V/60 Hz	18 1/8" x 16 1/8" x 10 3/4"	70 lbs.
Model J-95*	95 lbs.	8 GPM	1/3 HP	115V/60 Hz	27" x 17" x 10 1/4"	80 lbs.

\*Includes "S" Models.



441 Applewood Crescent  
Concord, Ontario L4K 4J3  
Ph. (905) 761-9000  
Fx. (905) 761-9001  
info@generalfiltration.com  
www.generalfiltration.com