

GF90SE

STYLE ONE

STYLE TWO

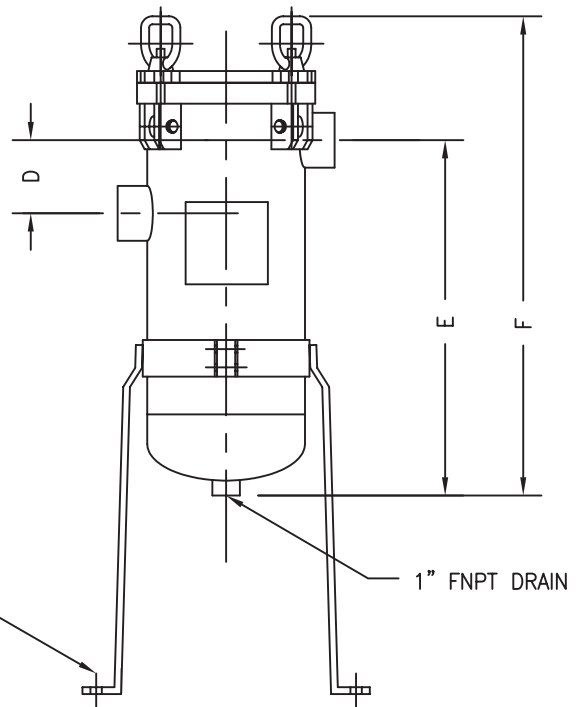
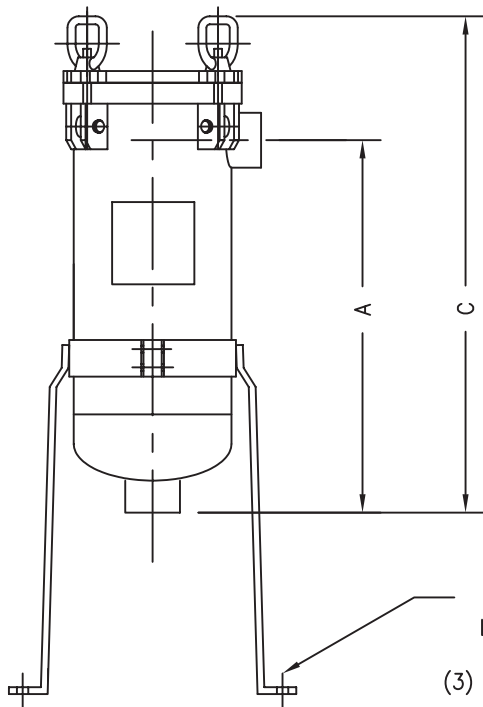
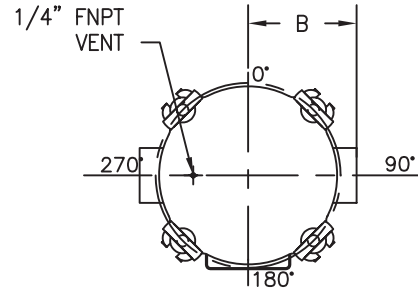
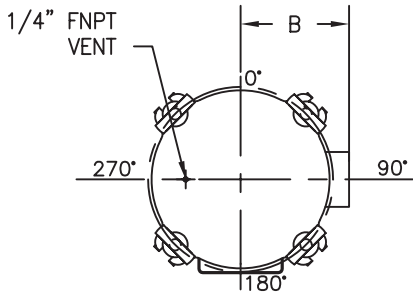

LEGS ADJUSTABLE FROM 0-12 IN.
(3) 5/8" DIA. HOLES

	FITTING SIZE	A	B	C	D	E	F
STD.	2" FNPT	20 1/2"	6 3/4"	26 1/2"			26 1/2"
	2 1/2" FNPT	20 3/4"	6 3/4"	27 1/2"	6"	20"	26 1/2"
	3" FNPT	21"	7"	28 1/2"	6"	20 1/2"	26 1/2"

SHIPPING WEIGHT	80 lbs
VOLUME	4 1/4 US. gal.
DESIGN PRESSURE	150 psig. @ 225 F