

GF180SE

STYLE ONE

STYLE TWO

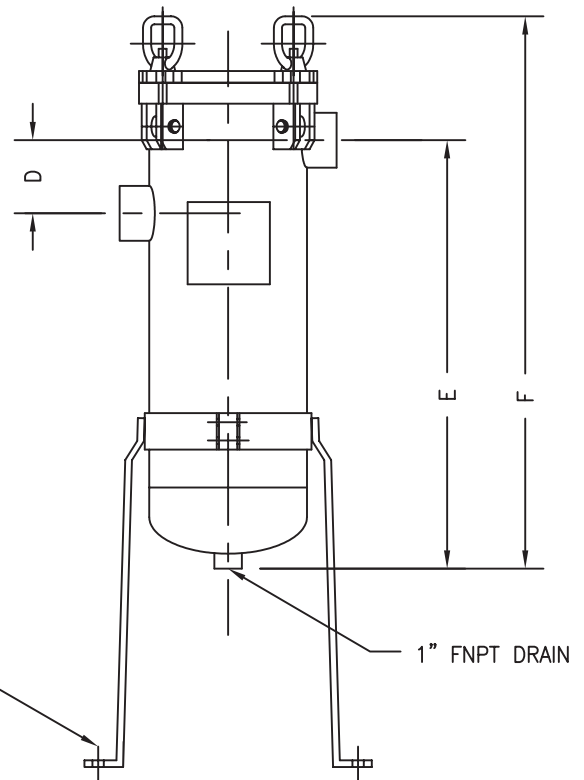
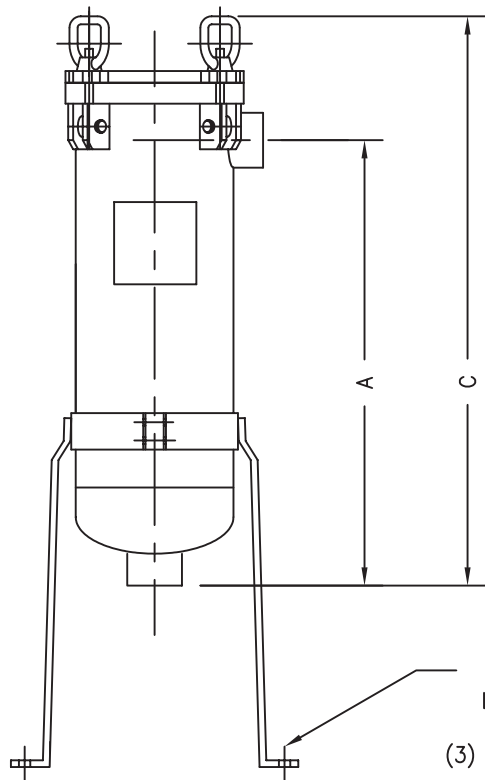
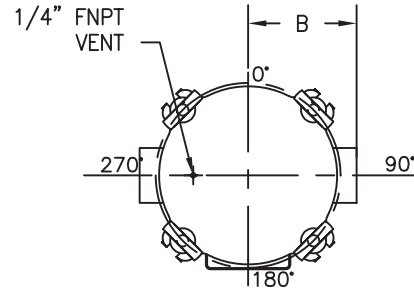
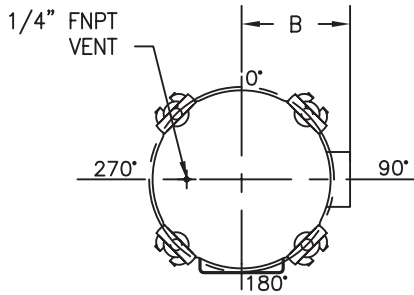

LEGS ADJUSTABLE FROM 0-12 IN.
(3) 5/8" DIA. HOLES

	FITTING SIZE	A	B	C	D	E	F
STD.	2" FNPT	33 1/2"	6 3/4"	40 1/2"	5		40"
	2 1/2" FNPT	34"	6 3/4"	41 1/2"	6"	34"	41"
	3" FNPT	34 1/2"	7"	42 1/2"	6"	34 1/2"	41 1/2"

SHIPPING WEIGHT	95 lbs
VOLUME	7 1/4 US. gal.
DESIGN PRESSURE	150 psig. @ 225 F